

HMF 2420-K



- power to lift.

HMF Kraantype 2420-K

Sterke alleskunner in de 24TM klasse, robuust, snel en veelzijdig

- De HMF 2420-K is uitgerust met het HMF HDL systeem (heavy duty lifting) voor extra hijscapaciteit.
- De knikgiek kan 15 graden doorknikken, ideaal bij werkzaamheden in kleine, lage ruimte's of hijsen door deuren en ramen.
- Kniehevel systeem op hoofd- en knikarm biedt optimale hijscapaciteit en haakbereik in het hele werkgebied.
- Het nieuw ontwikkelde HMF RCL 5300 veiligheidssysteem controleert alle kraanbewegingen, en geeft de benodigde informatie om hijswerkzaamheden goed en veilig uit te kunnen voeren.
- Het ontwerp van de HMF 2420-K is "strak en schoon". Bijv: de lasthoudkleppen zijn veilig en geflensd gemonteerd, en slangen en leidingen van steunpoten, kolom en hoofdgiek dmv interne doorvoering.
- Stabiliteit verzekerd door steunpoot spreiding 5575mm (optioneel 6455mm) of HMF's gepatenteerde EVS stabiliteitsbewakingssysteem.
- Steunpoten standaard vaste montage, optioneel manueel 20 grdn wegklapbaar, of 180 grdn hydraulisch opklapbaar.
- De kraan is o.a. verkrijgbaar met de volgende opties: radiografische afstandsbediening, lier, transport alarm, temperatuur controle, etc.

HMF 2420-K2

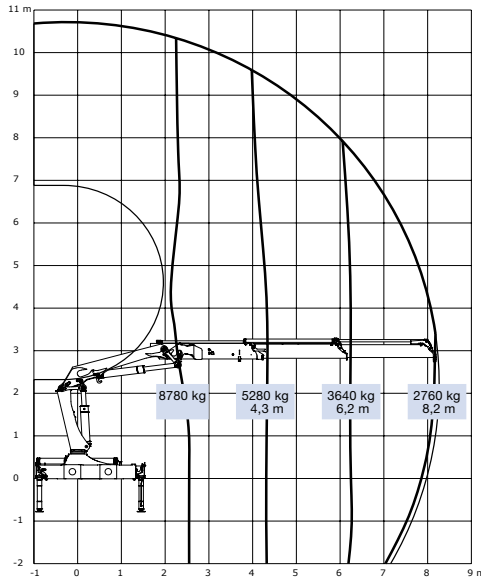

HMF 2420-K3

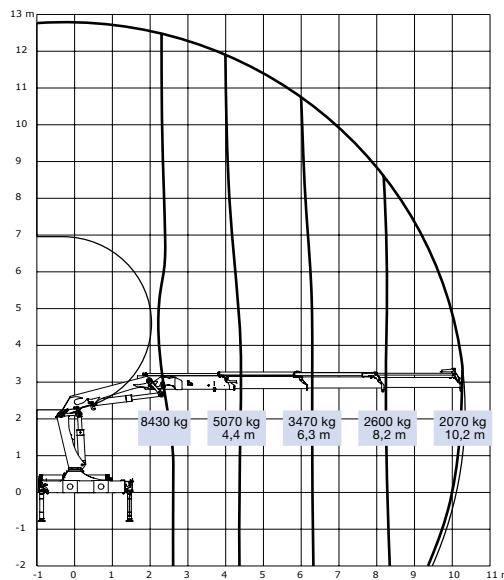

HMF 2420-K4

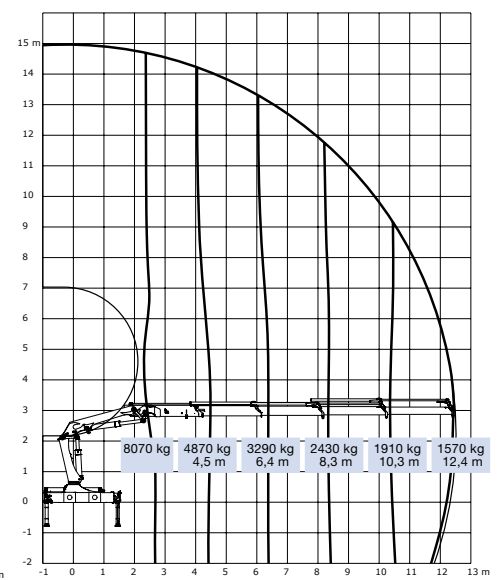

HMF 2420-K5

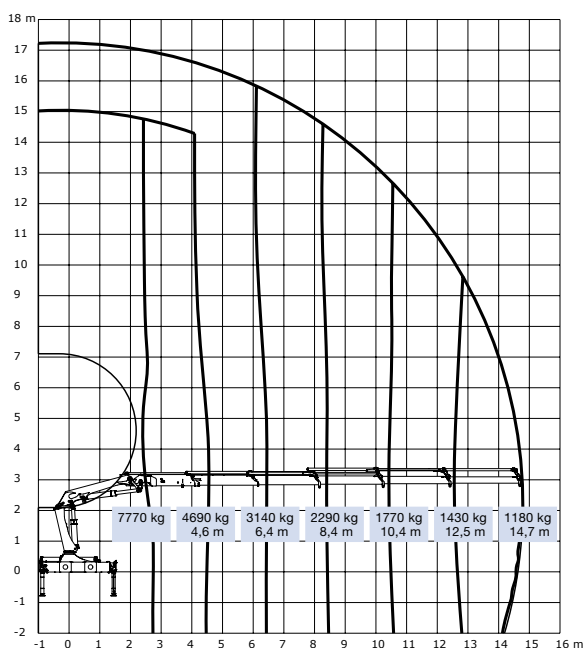

HMF 2420-K6

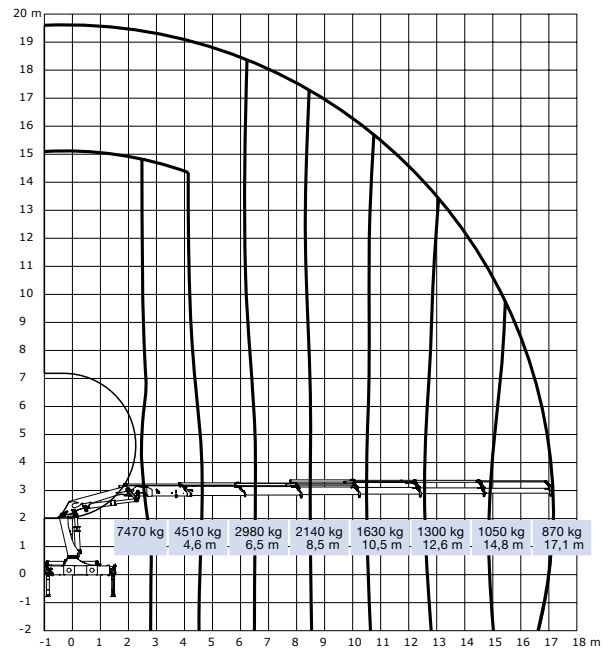

Kraangroep B3	Type	2420-K2	2420-K3	2420-K4	2420-K5	2420-K6	2420-K7	2420-K8
Last moment	Tm	22,9	22,4	21,8	21,4	20,9	20,6	20,1
Hydraulisch bereik	M	8,3	10,3	12,5	14,8	17,2	19,4	21,7
Zwenkmoment	Kgm	2762	2762	2762	2762	2762	2762	2762
Zwenkbereik	°	400	400	400	400	400	400	400
Max zwenkhoek (bij zwenkmoment)	°	5	5	5	5	5	5	5
Werkdruk	Bar	330	330	330	330	330	330	330
Pompflow	l/min	60	60	60	60	60	60	60
Hoogte ingevouwen	mm	2295	2295	2295	2295	2295	2295	2295
Opbouwlengthe (excl extra ventielen)	mm	880	880	880	880	880	990	990
Opbouwlengthe (incl extra ventielen)	mm	1000	1000	1000	1000	1000	-	-
Breedte ingevouwen	mm	2500	2500	2500	2500	2500	2500	2500
Steunpootspreiding standaard	mm	5575	5575	5575	5575	5575	5575	5575
Steunpootspreiding extra breed	mm	6455	6455	6455	6455	6455	6455	6455
Kraan gewicht excl steunpoten*	kg	1980	2150	2350	2500	2640	2745	2830
Gewicht steunpoten standaard*	kg	290	290	290	290	290	290	290
Gewicht steunpoten extra breed*	kg	365	365	365	365	365	365	365

* Gewichten excl montage materialen, olie en evt opties

HMF 2420-K7

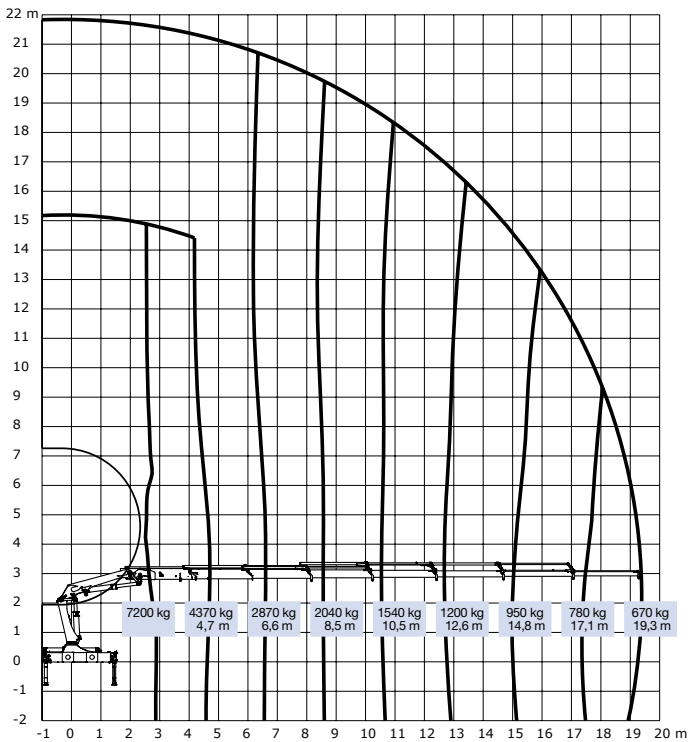

HMF 2420-K8

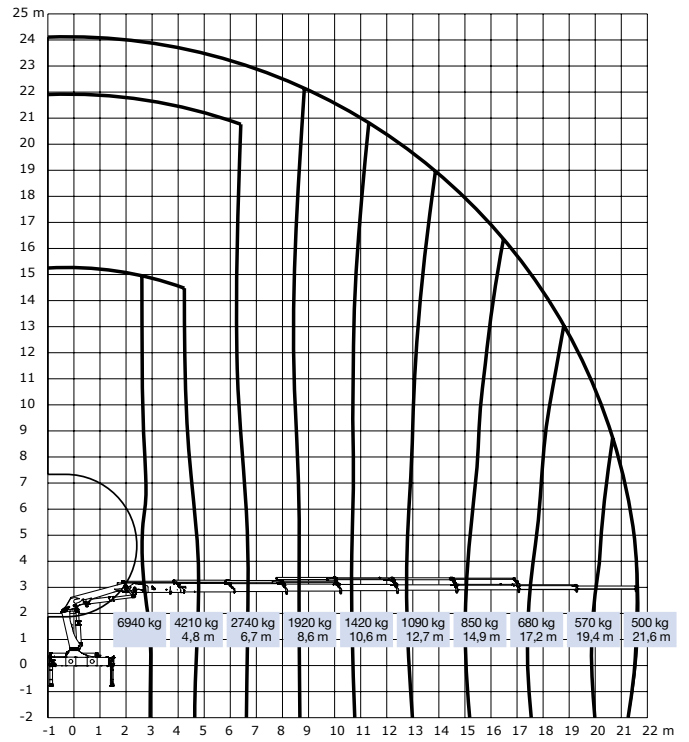

HMF 2420-K2

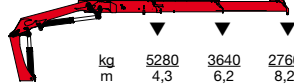

HMF 2420-K3

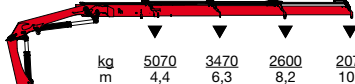

HMF 2420-K4



HMF 2420-K5

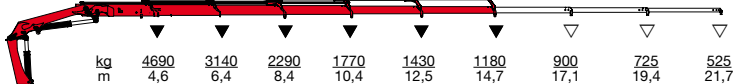

HMF 2420-K6

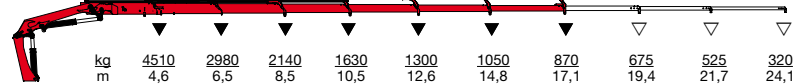

HMF 2420-K7

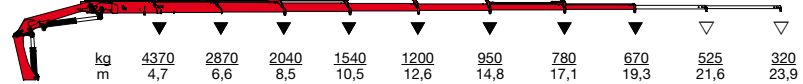

HMF 2420-K8

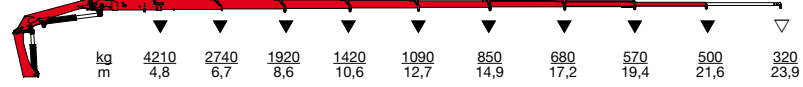

▼ Hijscapaciteit excl handdelen

▽ Hijscapaciteit incl handdelen

HMF Kraantype 2420-K

HMF 2420-K

HMF 2420-K4 / FJ600-K3

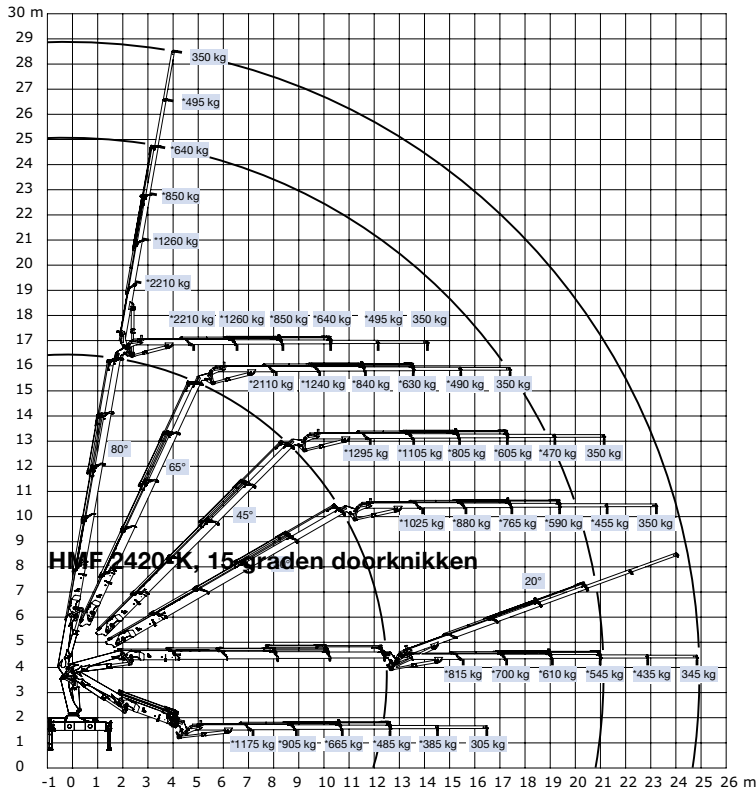

HMF 2420-K4 / FJ600-K4

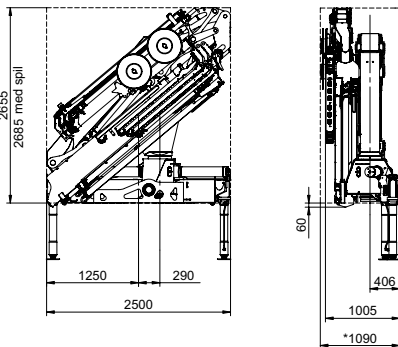
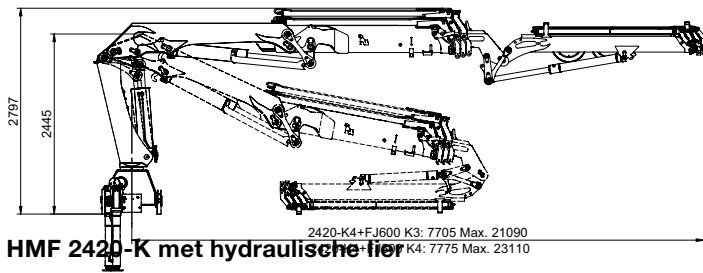
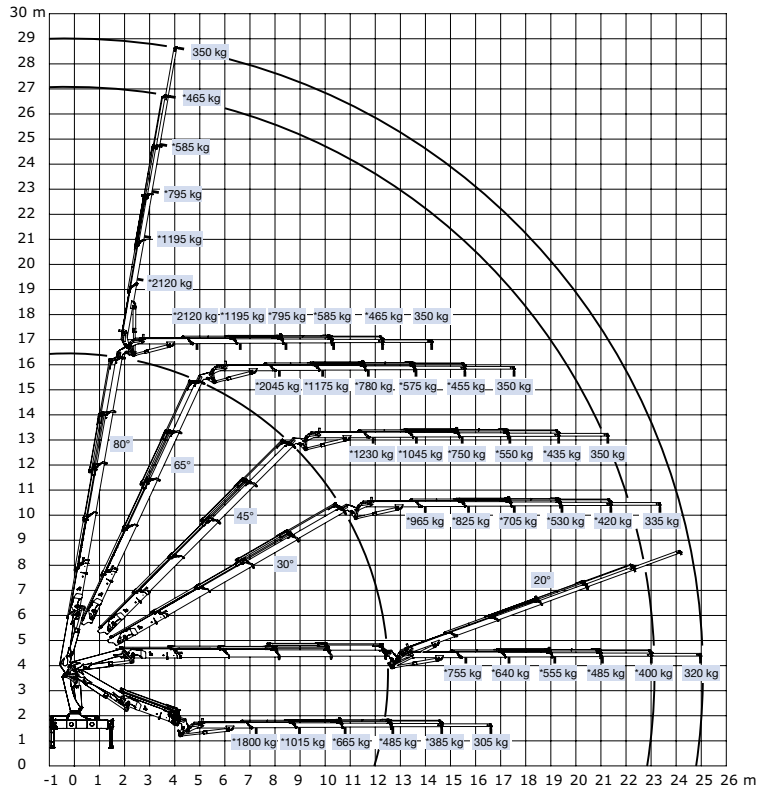

HMF 2420-K6 / FJ350-K4

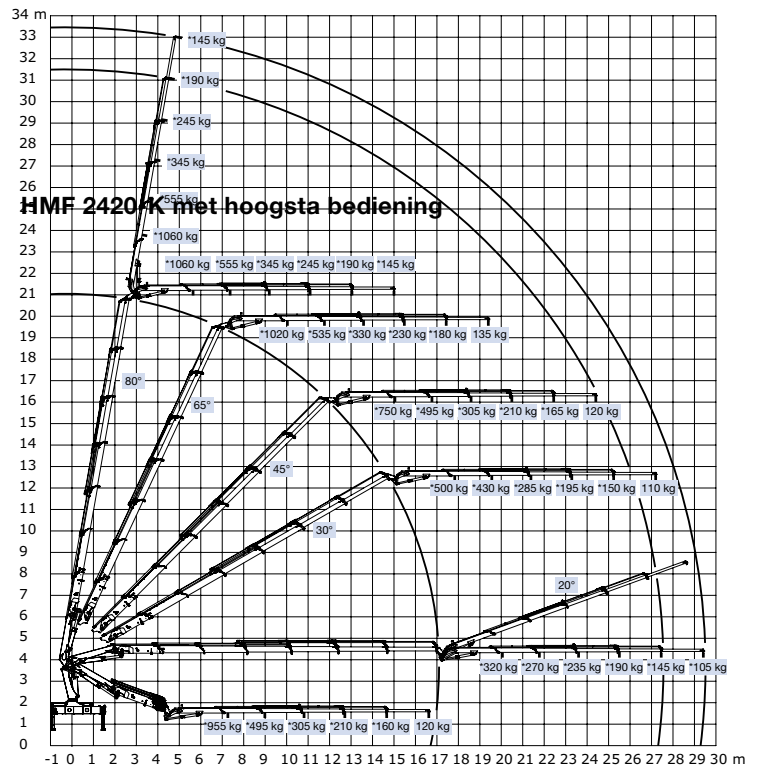

Z008441-1



Højbjerg Maskinfabrik A/S • Oddervej 200 • DK-8270 Højbjerg
Tel.: +45 8627 0800 • Fax: +45 8627 0744 • info@hmf.dk

www.hmf.dk

Wij behouden het recht om wijzigingen en/of modificaties door te voeren zonder kennisgeving.